

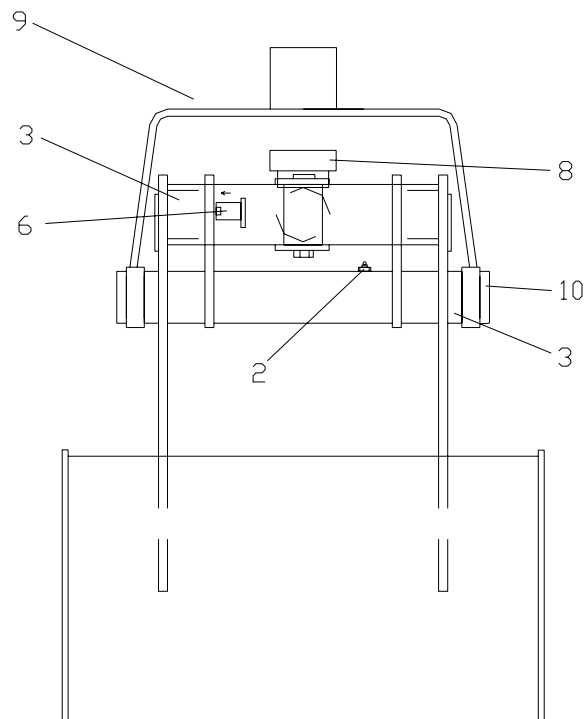

TECHNISCHE GEGEVENS:

Type knijperbak	: MNG
Mesbreedte	: 300, 350, 400, 450 en 500 mm
Hoogte (dicht)	: 526 mm
Hoogte (open)	: 366 mm
Sprei	: 759 mm
Inhoud	: 50, 60, 70, 80 en 90 L
Eigen gewicht:	: 50, 55, 60, 65 en 70 kg

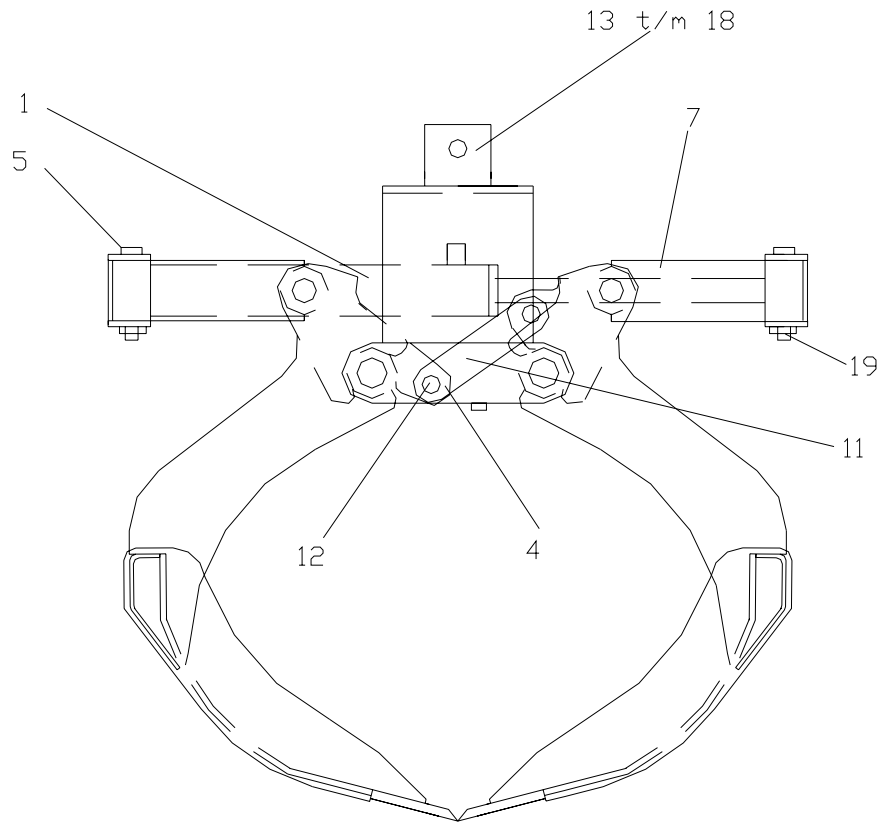



Onderdelenlijst openschalengrijper mini model

tek.ref.nr.	Artikel Code	Aantal	Omschrijving
	1981002	4	Bout M 8 x 25 met veerring
	1980802	8	Bout M 8 x 25 (zijplaten)
	1980820	8	Moer M 8 (zijplaten)
	1980600	2	Bout M 6 x 20
1	1919030	1	Cilinder D25/40/200
	1919031	1	Afdichtingsset 25/40
2	1970001	6	Vetnippel
3	1974006	8	Klembus 25/32/30
4	1974008	2	Klembus 20/24/10
5	1919301	2	Cilinderpen
6	1919302	4	Juk pen
7	1919303	2	Juk
	1919304	1	Pen (rotatorbus)
8	1912003	1	Dubbelgestuurde terugslagklep 3/8
9	1919305	1	Bovenbok
10	1919306	2	Bovenbok as
11	1919307	1	Gelijkloper
12	1919308	2	Gelijkloop pen
13	1919309	1	Rotatorbus as 60 gat 30
14	1919310	1	Rotatorbus as 70 gat 30
15	1919311	1	Rotatorbus as 50 gat 25
16	1919312	1	Rotatorbus as 70 gat 25
17	1919313	1	Rotatorbus as 40 gat 20
18	1919314	1	Rotatorbus as 63 gat 30
	1919201	1	Set slangen Cilinders
	1919202	1	Set slangen OSG/Rotator
	1919203	1	Set slangen Rotator/Kraan
19	1973050	2	Spanstift 8 x 40