



OPERATING MANUAL

Grab Bucket BDV 60-23



Please read this manual carefully before using this product!

CONTENTS

1. OPERATIONAL CONDITIONS	3
2. ASSEMBLING/DISMANTLING:	
2.0 THE CONNECTOR PLATE	4
2.1 THE ROTATOR	4
2.2 THE HOSES FROM CRANE TO ROTATOR	5
2.3 THE HOSES BETWEEN ROTATOR AND CYLINDER	5
2.4 THE LINK	6
2.5 THE DETACHABLE SIDE PLATES	6
2.6 USE OF THE HOISTING HOOK	6
2.7 THE RUBBER JAWS	7
2.8 THE SADDLE PLATE	8
2.9 THE CYLINDERS	8
3. MAINTENANCE AND REPAIR	9
4. TROUBLE SHOOTING	9
TECHNICAL DATA	10/11
PARTS GRAB	12/13
PARTS CYLINDER	14/15

© 2010 Bakker Hydraulic Products B.V.
Nijverheidsweg 6

6662 NG Elst (Gld) The Netherlands

Tel : + 31 481 374757

Fax : + 31 481 375280

Site : www.bakker-hydraulic.com

E-mail : info@bakker-hydraulic.com

1. OPERATIONAL CONDITIONS

Operation of the grab is prohibited unless the whole machine of which the grab forms part has been deemed and certified as conforming to the provisions of the Machine Guideline 2006/42/EC (most recently amended version).

This product is a universal grab bucket, which is also known as the Jack-of-all-trades of grab buckets.

Wood, tree-branches, rubble, sand and gravel... this grab bucket can tackle almost anything. Also ideal for excavation and digging in earth and light clay.

Using detachable side plates, delivered separately, you can also use this grab bucket to load gravel, grit, and the like.

Special separate rubber jaws can be supplied for moving complete packages of tiles. These rubber jaws can be very easily fastened to the grab bucket casing in a single action.

This product is *not* suitable for *breaking asphalt, uprooting trees or loading scrap onto lorries etc.* if it is unevenly loaded (crowbar effect).

Notes :

When designing this product, account was taken not only of normal usage but also of usage to be reasonably expected.

If the customer modifies the product without the manufacturer's knowledge, the customer (the user) is liable for the consequences and the guarantee becomes null and void.

Maintenance is, of course, permitted, providing it is carried out according to the instructions provided in the manual.

Warning : Ensure that there are no people within working range of this product when it is being used!

Caution : During transport, secure the grab bucket to the loading platform or to the machine itself.

Take note of the maximum headroom!

© 2010 Bakker Hydraulic Products B.V.
Nijverheidsweg 6

6662 NG Elst (Gld) The Netherlands

Tel : + 31 481 374757

Fax : + 31 481 375280

Site : www.bakker-hydraulic.com

E-mail : info@bakker-hydraulic.com

2. ASSEMBLING/DISMANTLING :

2.0 THE SUSPENSION PLATE :

Assembly :

Place the suspension plate on the saddle plate. Check that the bolt-holes in the suspension plate and the saddle plate correspond with each other. Fit the 4 bolts and nuts) supplied. Tighten everything properly. After using the product the next time, check the bolts for tightness and retighten them if necessary.

N.B.:

Always fit the nut on top. Before fitting the suspension plate, determine first how the hoses will run from your rotator to the cylinder.

2.1 THE ROTATOR :

2.1.1 Assembling the rotator drive shaft :

Place the rotator drive shaft in the suspension plate. If the outside measurements of the rotator shaft do not correspond with the inside measurements of the suspension bush, you probably have the wrong suspension plate for your rotator. If so, contact your supplier. Rotate your rotator shaft until the hole in the rotator shaft is in front of the suspension bush hole. After this, mount the suspension pin and the hairpin spring.

2.1.2 Assembling the rotator with flange fitting :

If you are using a rotator with a flange fitting, the drill-hole pattern in the saddle plate must correspond with the drill-hole pattern in the rotator.

Now, you just fasten the rotator to the saddle plate with a bolt joint, according to the instructions of the rotator supplier.

2.2 THE HOSES FROM CRANE TO ROTATOR :

The rotator hose connections used for rotation are fitted with throttle valves. You may not use the rotator without these throttle valves. The hoses from the crane to the rotator used for rotation must be connected to a connection point supplied with a throttle valve. The hoses from the crane to the rotator, which are used for grabbing, must be connected to the two remaining connection points on the rotator.

Note :

If it appears that the operation of the grab bucket and/or rotator does not correspond with the data on your operating handles, then you have probably connected the hoses incorrectly.

2.3 The hoses between rotator and cylinder :

Note :

When using a rotator purchased from Bakker Hydraulic Products BV, the hoses that connect this rotator and the hydraulic cylinder should be ordered from the manufacturer. You can then be sure that the hoses are the right length and diameter. If required, reinforced hoses can be supplied as extras by and in consultation with the manufacturer.

2.3.1 Mounting the hoses on a rotator with drive shaft :

Fit a hose to one of the hose connections on the rotator shaft (ensure that you have the right diameter hose). Now fasten the other end of this hose to one of the connections on the cylinder. Repeat this to connect the second hose.

Note :

If the grab bucket does not function properly after mounting the hoses, swap around the hoses from the crane to the rotator. If the grab bucket still does not operate to your complete satisfaction, contact the manufacturer or your nearest dealer.

2.3.2 Mounting the hoses on a rotator with flange fitting

To fit the hose to the hose connection on the hydraulic cylinder, see Section 2.4.1 above.

To connect the hose to the rotator, please refer to the rotator manufacturer.

© 2010 Bakker Hydraulic Products B.V.
Nijverheidsweg 6

6662 NG Elst (Gld) The Netherlands

Tel : + 31 481 374757

Fax : + 31 481 375280

Site : www.bakker-hydraulic.com

E-mail : info@bakker-hydraulic.com

2.4 THE LINK :

Assembly :

A link is always mounted between the rotator and the jib of the crane.
Mount the link at the top of the rotator.
Mount the link pin and locking pin.
Check whether the link can move freely.
Connect and lock the link to the crane.

Note :

Make sure that there is as little sideways slack as possible. If necessary, mount spacers.

2.5 THE DETACHABLE SIDE PLATES :

Assembly :

A standard feature of the grab bucket is that it has holes for fastening detachable side plates. The detachable side plates (one set = four plates), which are supplied as extras, can be fixed to the sides of the grab bucket by means of a few bolts.

To do this, mount two side plates to one side of the grabber and adjust them so that the grab bucket closes properly (using the slotted holes in the detachable side plates). Now tighten the bolts well.

Do the same on the other side of the grab bucket. Your grab bucket with side plates is now ready for use.

Caution : Only use detachable side plates when loading loose material!

2.6 USE OF THE HOISTING HOOK

Open the grab bucket completely and place it on a solid surface.
Disconnect the hydraulic hoses of the grab bucket (grab/rotator). Attach the load to the hoisting hook using a chain suitable for the load. Now lift the object to be hoisted in a controlled manner.

- The grapple must rest on the surface at all times when connecting and disconnecting the chain/noose to/from the hoisting hook.

© 2010 Bakker Hydraulic Products B.V.
Nijverheidsweg 6

6662 NG Elst (Gld) The Netherlands

Tel : + 31 481 374757

Fax : + 31 481 375280

Site : www.bakker-hydraulic.com

E-mail : info@bakker-hydraulic.com

- When the hoisting hook is in use, no persons may be in the danger zone (under or in close proximity of the grapple).
- The load must always be straight below the hoisting hook. Make sure that chains/nooses and such cannot come into contact with the blades/jaws of the grapple.

2.7 THE RUBBER JAWS :

Assembly:

The rubber jaws are available as standard accessories in two different versions and are fitted with rubber (70° shore):

- Total length = 47"
- Total length = 67"

When mounting the tile jaws, ensure that the grab bucket is in the open position.

Lay the tile jaws on the ground with the rubbers opposite each other, roughly 50" apart.

Position the grab bucket above the rubber jaws and slowly lower it until the blades of the grab bucket are in the appropriate position for the rubber jaws.

After this, slide the hooks (on the load binders) over the top of the side panel.

Now hook the chain of the rubber jaw to the load binder and tighten and lock the whole structure.

Make sure that the rubber jaw is not loosely suspended.

Note :

When ordering the above rubber jaws, always specify the type and width of the grab bucket to which the rubber jaws must be mounted.

Also specify the required length of the rubber jaws.

If the rubbers are worn, they must be replaced with new ones.



2.8 THE SADDLE PLATE :

2.8.1 Dismantling the saddle plate :

Undo the two M10 bolts and remove the so-called "locking spanner", which is fastened to the bottom strip of the saddle plate.
Use this spanner to undo the two locking nuts.
Undo the two M10 bolts and remove the two shafts.
Now the saddle plate can be removed without any problems.

2.8.2 Assembling the saddle plate :

Assemble the saddle plate in the reverse order to which you dismantled it.

2.9 THE CYLINDERS :

Removing the cylinder :

Place the grab bucket in the closed position and make sure it is stable.
Remove the pins at each end of the cylinder.
Pull in the piston rod with the aid of oil pressure and make sure when doing so that the cylinder ends are protected from damage.
Once this has been done, the cylinder can be removed in its entirety.

Dismantling the cylinder :

Unscrew and remove the head bush.
When the head bush is removed, carefully remove the piston rod.

Caution!

Take care not to damage the piston rod.
To replace the seals, you must first remove the outer cylinder tube.
The non-return valve can be removed and mounted at all times without any problems, providing there is no pressure on the cylinder.

© 2010 Bakker Hydraulic Products B.V.
Nijverheidsweg 6

6662 NG Elst (Gld) The Netherlands

Tel : + 31 481 374757

Fax : + 31 481 375280

Site : www.bakker-hydraulic.com

E-mail : info@bakker-hydraulic.com

Reassembling the cylinder :

Assemble the cylinder parts in the reverse order to which you dismantled them.

N.B.:

When mounting the head bush, you must use Loctite type 243 or a comparable locking agent.

3. MAINTENANCE AND REPAIR

- Check the hoisting hook visually once a year, and test the hook once every 4 years with an 22000 lbs load divided into 11000 lbs per hook.
- Test the non-return valve once a year to ensure that it is working properly.
- Check pins and bushes every year for slack (maximum 5/16").
- If the exchangeable blades are worn, they must be replaced by new blades (maximum 1" per blade edge).
- Regularly grease the pivots (steady link, cylinder suspension and pins) to prevent penetration of sand, dirt, etc.
- After 20 working hours, check all bolted connections and tighten if necessary.

Caution!

With all maintenance activities on the grab bucket, the grab bucket must be non-operational and stationed on the ground.

Without lubrication	Tightening torque
M 8 8.8	14 lbf-ft
M 10 8.8	27 lbf-ft
M 12 8.8	48 lbf-ft
M 16 8.8	120 lbf-ft
M 16 10.9	221 lbf-ft

© 2010 Bakker Hydraulic Products B.V.
Nijverheidsweg 6

6662 NG Elst (Gld) The Netherlands

Tel : + 31 481 374757

Fax : + 31 481 375280

Site : www.bakker-hydraulic.com

E-mail : info@bakker-hydraulic.com

4. TROUBLESHOOTING

Problem : Load is no longer held.

Possible causes :

- Non-return valve and/or seals
- Piston seals worn
- External leakage's to cylinder tube

Tips for tracing faults :

- The cylinder may not display any external leakage's. If it does, check that the head bush is tight. If the head bush is loose, the seals must be replaced.
- With the grab bucket in the open position, disconnect the hoses from the crane and check whether the grab bucket automatically closes when freely suspended.

If it does :

- the non-return valve and/or seals are/is defective
- check the piston seals and replace if necessary.

TECHNICAL DATA :

Grab type : BDV 60-23

Width : 23"

Capacity : 8.5 bushel

Weight : 725 lbs

Max. working pressure : 2900 psi

Press strength : 4500 lbf

Maximum oil flow in non-return valve: 10 gpm.

© 2010 Bakker Hydraulic Products B.V.
Nijverheidsweg 6

6662 NG Elst (Gld) The Netherlands

Tel : + 31 481 374757

Fax : + 31 481 375280

Site : www.bakker-hydraulic.com

E-mail : info@bakker-hydraulic.com

Max. hoisting load:

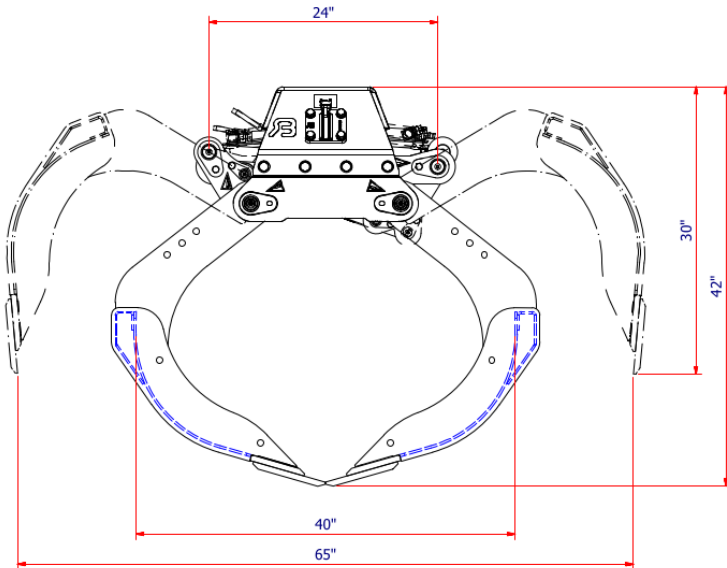
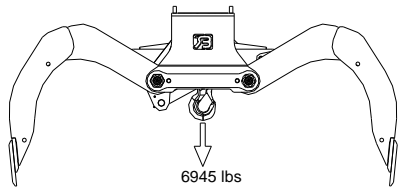
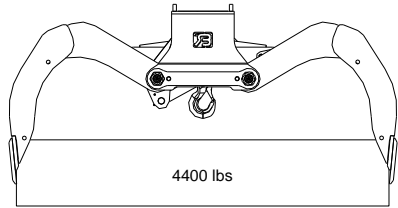

© 2010 Bakker Hydraulic Products B.V.
 Nijverheidsweg 6

6662 NG Elst (Gld) The Netherlands

Tel : + 31 481 374757

Fax : + 31 481 375280

Site : www.bakker-hydraulic.com

E-mail : info@bakker-hydraulic.com

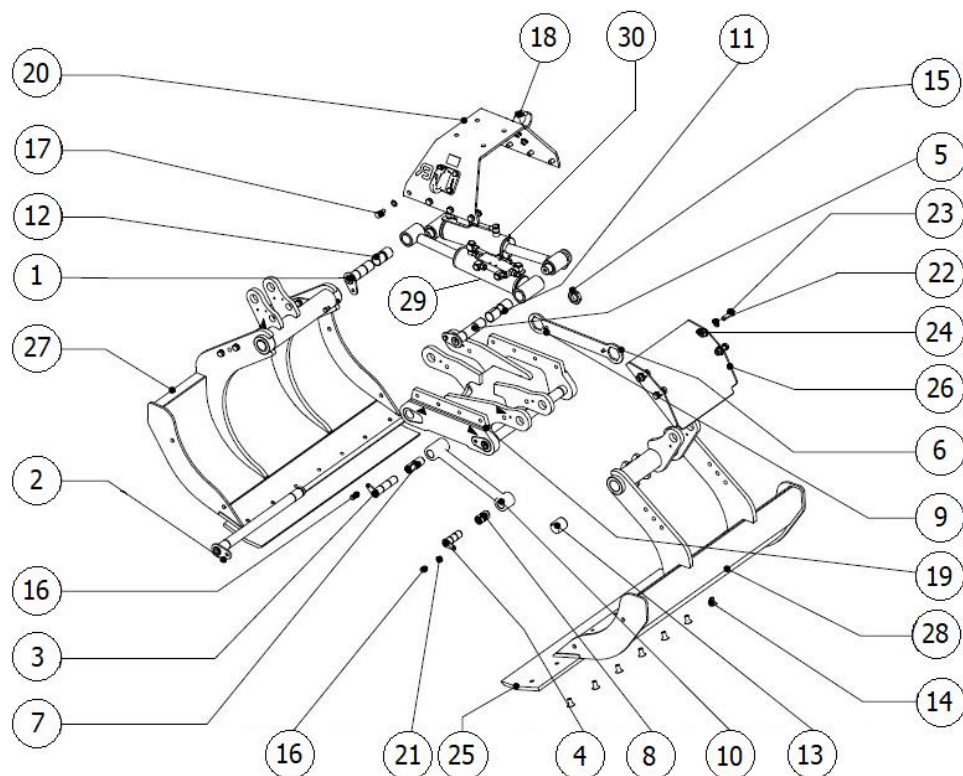

© 2010 Bakker Hydraulic Products B.V.
Nijverheidsweg 6

6662 NG Elst (Gld) The Netherlands

Tel : + 31 481 374757

Fax : + 31 481 375280

Site : www.bakker-hydraulic.com

E-mail : info@bakker-hydraulic.com

POS	PART NUMBER	QUANTITY	SPECIFICATION
1	7101	2	PIN
2	7102	2	SHAFT
3	7103	1	PIN
4	7104	1	PIN
5	7105	2	PIN
6	7114	1	LOCKING SPANNER
7	7338	2	SLEEVE BEARING
8	7339	2	SLEEVE BEARING
9	7408	8	BOLT
10	7434	1	STEADY LINK
11	7435	4	SLEEVE BEARING
12	7436	4	SLEEVE BEARING
13	9003	4	SPLIT BUSH
14	9025	10	BOLT
15	9205	2	NUT
16	9206	8	BOLT
17	9295	8	BOLT
18	75049	2	HOISTING HOOK
19	75177	1	BASE
20	75509-10	1	SADDLE PLATE
21	75221-10	6	LOCKING SPRING
22	75221-16	16	LOCKING SPRING
23	75258	8	BOLT
24	75261-16	8	LOCKING NUT
25	75378-48	2	BLADE
26	75470	2	PROTECTION PLATE
27	75473-48	1	SHELL
28	75506-48	1	SHELL
29	75854	1	CYLINDER
30	75854-1	1	CYLINDER INCL. VALVE KIT

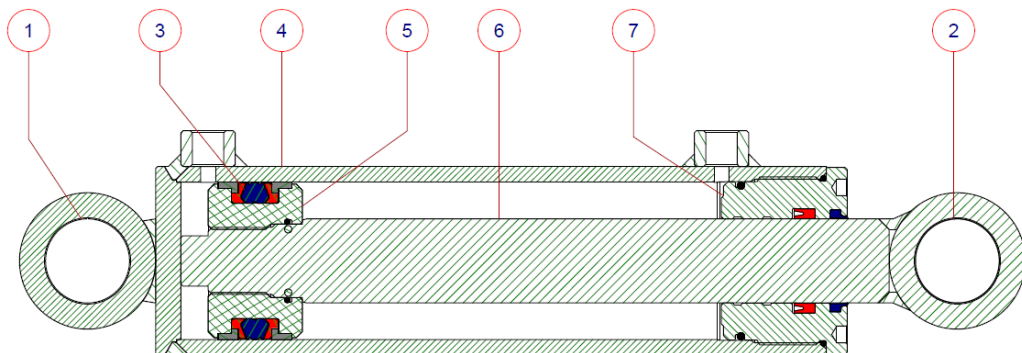

POS	PART NUMBER	SPECIFICATION
1	7435	SLEEVE BEARING
2	7436	SLEEVE BEARING
3	1919059	CYLINDER SEALS
4	1919062	CYLINDER CASING
5	1919060	PISTON
6	1919061	PISTON ROD
7	1919063	HEAD BUSH

© 2010 Bakker Hydraulic Products B.V.
Nijverheidsweg 6

6662 NG Elst (Gld) The Netherlands

Tel : + 31 481 374757

Fax : + 31 481 375280

Site : www.bakker-hydraulic.com

E-mail : info@bakker-hydraulic.com

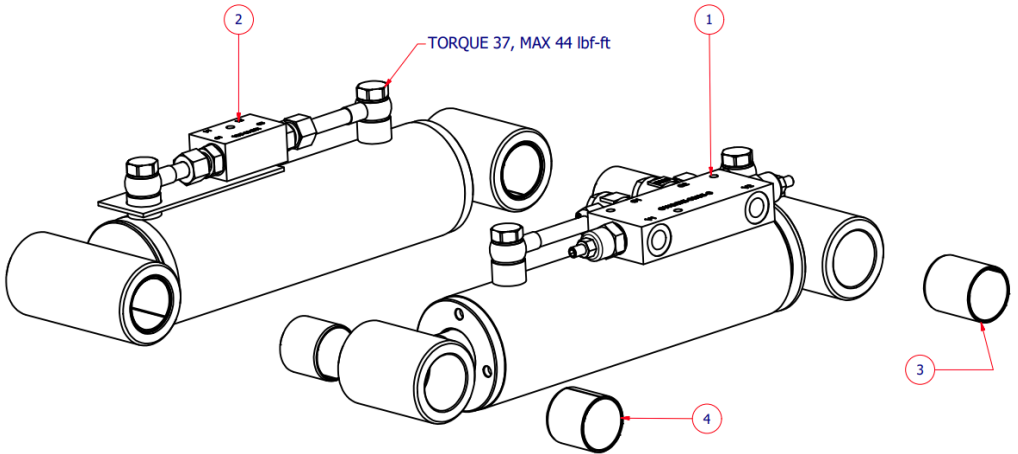

POS	PART NUMBER	SPECIFICATION
1	1919207	BRAKE VALVE
2	75886-1	NON-RETURN VALVE COMPLETE
3	7435	SLEEVE BEARING
4	7436	SLEEVE BEARING