

## TECHNISCHE GEGEVENS:

Type hakengrijper	: GEJO 10
Hoogteverstelling	: 600 mm
Gewicht	: 215 Kg
Maximale werkdruk	: 200 Bar
Maximale hijslast	: 4 ton
Maximale oliedoorvoer	: 20 l/min
Elektrische aansluiting	: 24 volt DC

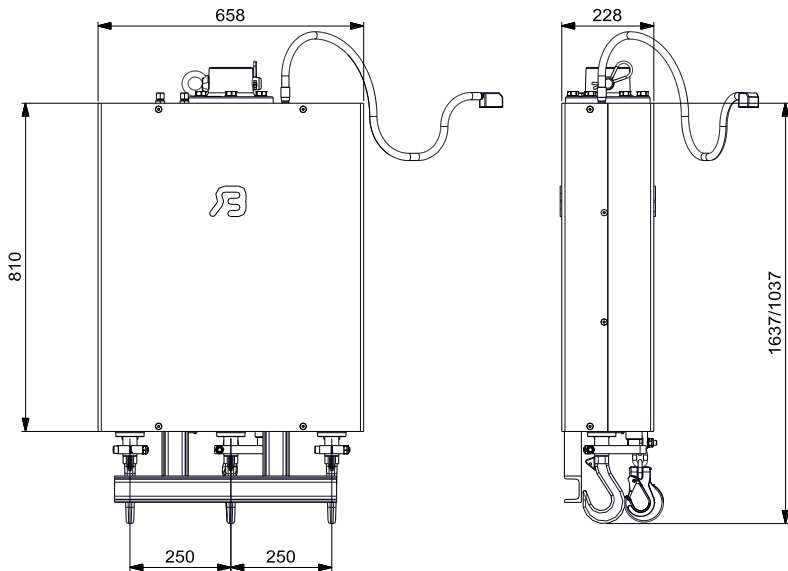

© 2010 Bakker Hydraulic Products B.V.  
Nijverheidsweg 6

6662 NG Elst (Gld) Holland

Tel : + 31 481 374757

Fax : + 31 481 375280

Site : [www.bakker-hydraulic.com](http://www.bakker-hydraulic.com)

E-mail : [info@bakker-hydraulic.com](mailto:info@bakker-hydraulic.com)

# Elektrisch en hydraulisch aansluitschema

## Stappenschakelaar

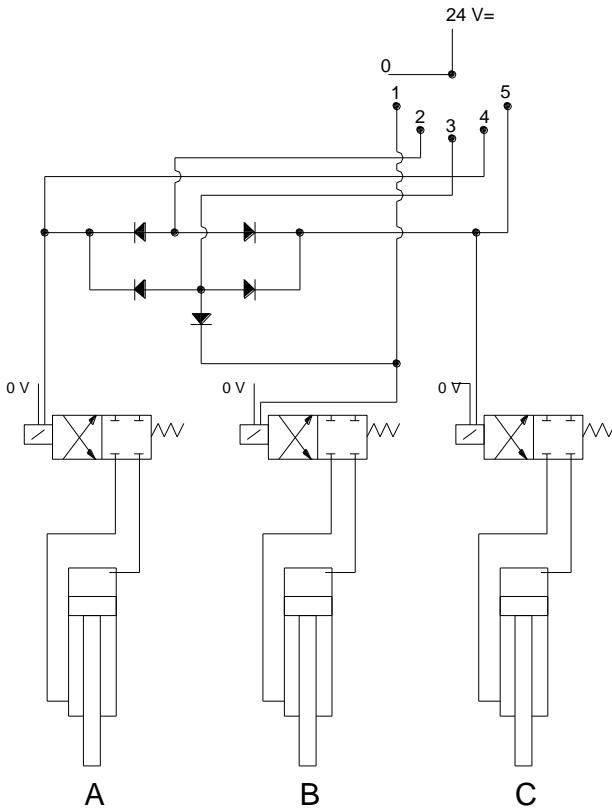

1	B
2	A + C
3	A + B + C
4	A
5	C

© 2010 Bakker Hydraulic Products B.V.  
Nijverheidsweg 6

6662 NG Elst (Gld) Holland

Tel : + 31 481 374757

Fax : + 31 481 375280

Site : [www.bakker-hydraulic.com](http://www.bakker-hydraulic.com)

E-mail : [info@bakker-hydraulic.com](mailto:info@bakker-hydraulic.com)

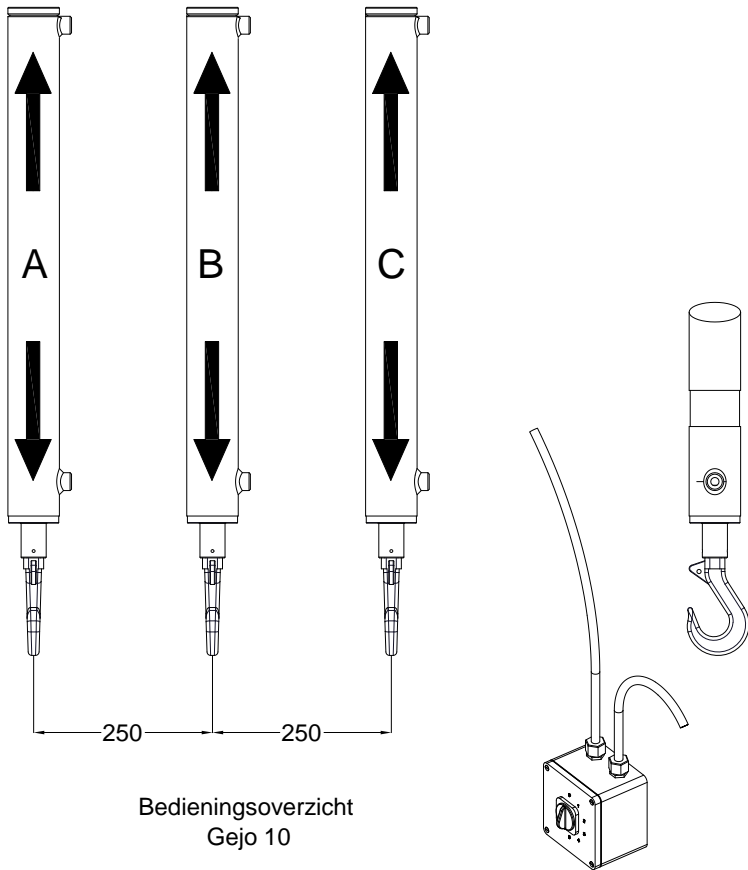

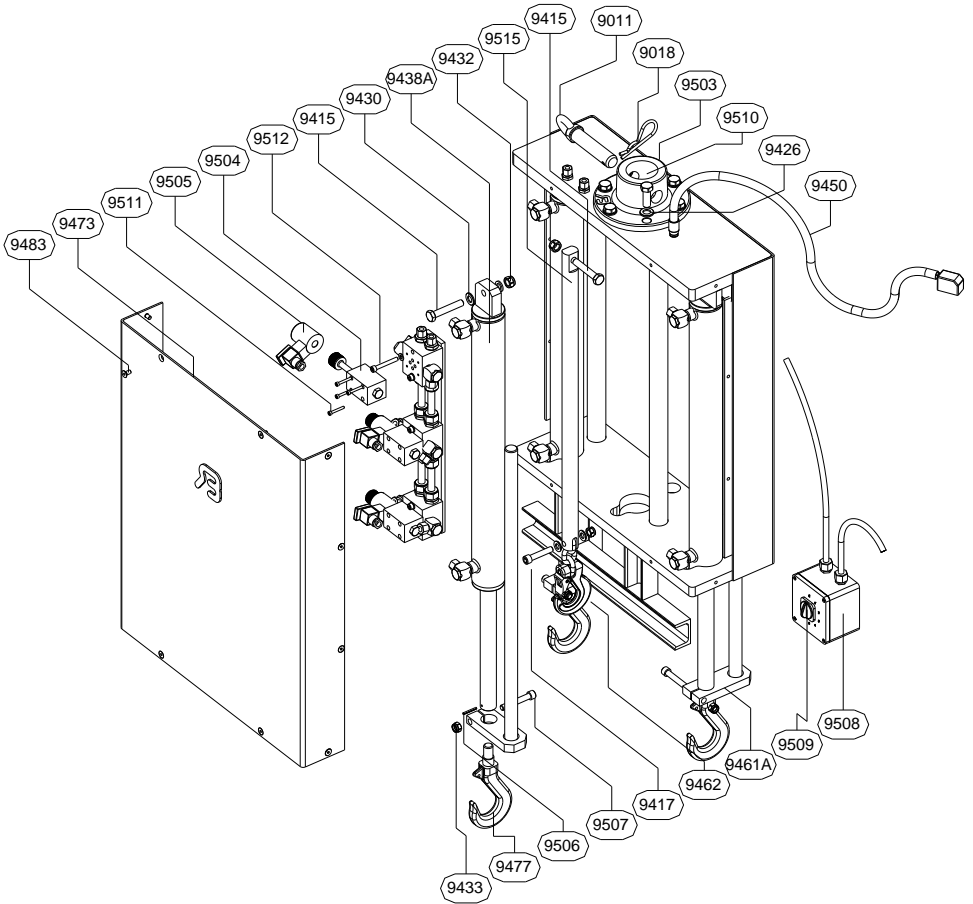
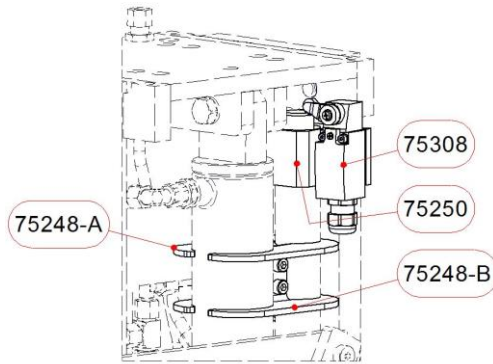

© 2010 Bakker Hydraulic Products B.V.  
Nijverheidsweg 6

6662 NG Elst (Gld) Holland

Tel : + 31 481 374757

Fax : + 31 481 375280

Site : [www.bakker-hydraulic.com](http://www.bakker-hydraulic.com)

E-mail : [info@bakker-hydraulic.com](mailto:info@bakker-hydraulic.com)

## ONDERDELENLIJST

Nr.	Omschrijving	Aantal
9011	Adapterpen	1
9018	Borgveer t.b.v. adapterpen	1
9415	Bout	4
9417	Inbusbout	1
9426	Sluitring	6
9430	Veerring	3
9432	Nyloc moer M 14	4
9433	Nyloc moer M 12	4
9438A	Cilinder 35-60-600 hakengrijper rev A	3
9450	Aansluitlang GEJO 10/20	1
9451	Aansluitset inwendig GEJO 10/20	1
9461A	Zuigerstangeleiding rev A	3
9462	Hulphaak	1
9473	Beschermkap voor GEJO 10	1
9477	Haak t.b.v. cilinder 9437A/9438A	3
9483	Bout	10
9503	Adapterplaat	1
9504	Wisselventiel hakengrijper compleet	3
9505	Spoel 24V t.b.v. wisselventiel 9504	3
9506	Spanstift	3
9507	Bout	3
9508	Aansluitset incl. 5 standenschakelaar	1
9509	5 standenschakelaar	1
9510	Bout	6
9511	Bout	12
9512	Bout	6
9515	Trekstang	1
75248-A	Klembeugel	1
75248-B	Klembeugel	1
75250	Schakelklem	1
75308	Beveiligingsschakelaar	1

© 2010 Bakker Hydraulic Products B.V.  
Nijverheidsweg 6

6662 NG Elst (Gld) Holland

Tel : + 31 481 374757

Fax : + 31 481 375280

Site : [www.bakker-hydraulic.com](http://www.bakker-hydraulic.com)

E-mail : [info@bakker-hydraulic.com](mailto:info@bakker-hydraulic.com)

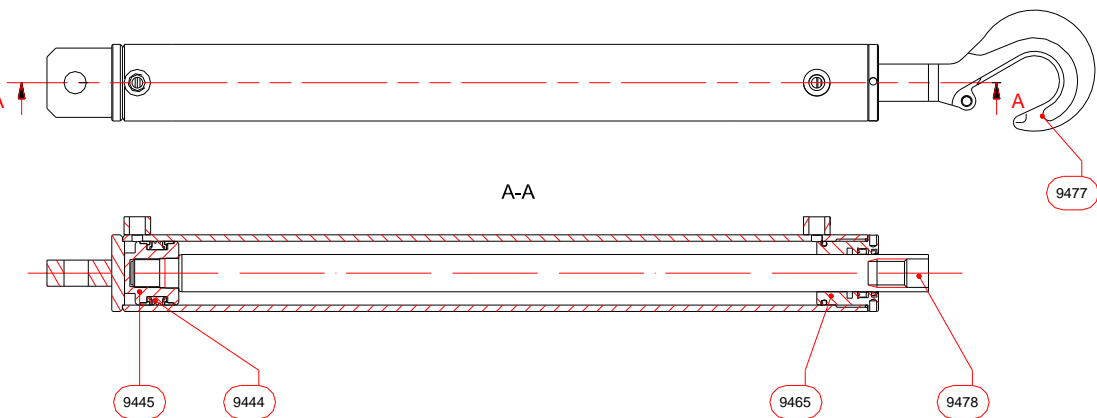

9444	Afdichtingsset
9445	Zuiger
9465	Kopmoer
9477	Haak
9478	Zuigerstang