

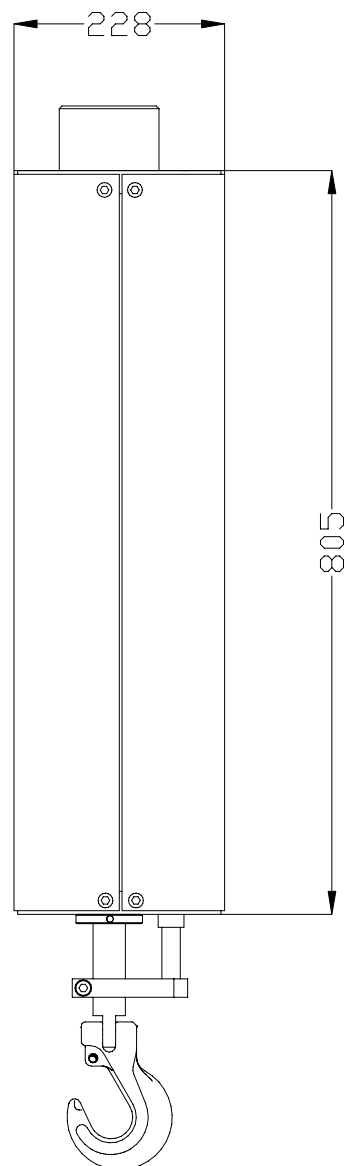

TECHNISCHE GEGEVENS:

Type hakengrijper	:	GEJO 10 rev. A
Vaste breedte	:	250 mm
Hoogteverstelling	:	600 mm
Gewicht	:	215 Kg
Maximale werkdruk	:	220 Bar
Maximale hijslast	:	3 ton
Maximale oliedoorvoer	:	80 l/min
Elektrische aansluiting	:	24 volt DC

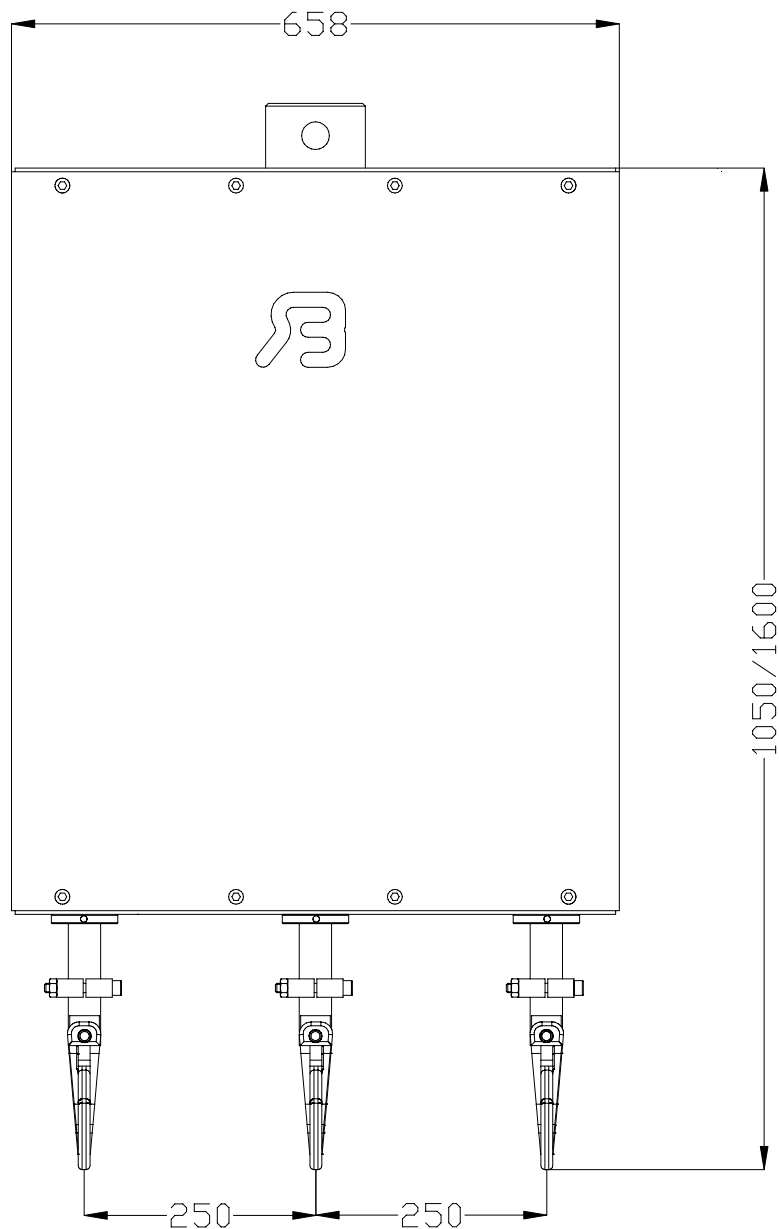



Stappenschakelaar

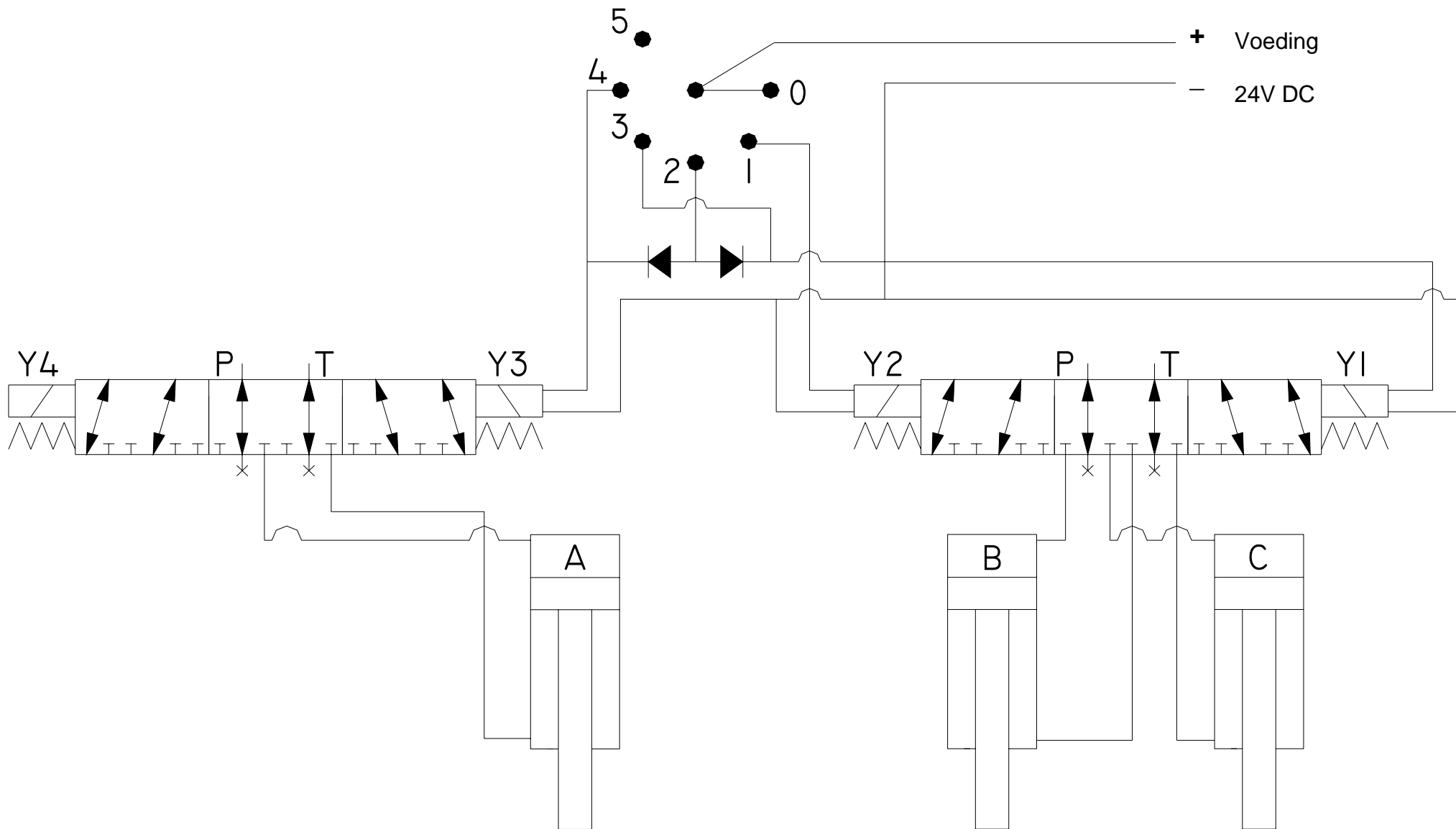

**Elektrisch en hydraulisch
aansluitschema GEJO 10 hakengrijper**

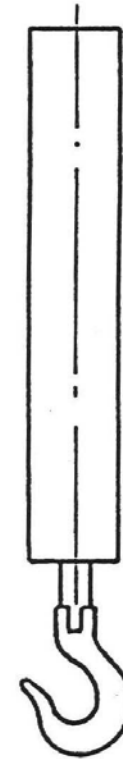
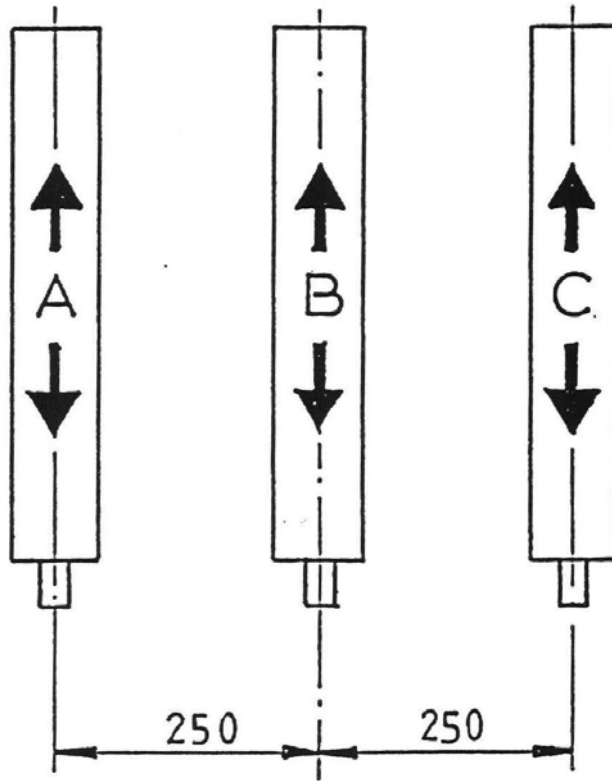

<u>SCHAKEL STAND</u>	<u>CILINDER</u>
1	B
2	A+C
3	C
4	A

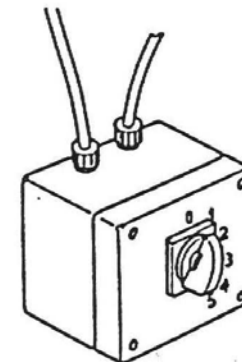

**Bedieningsoverzicht
 GEJO 10 hakengrijper**

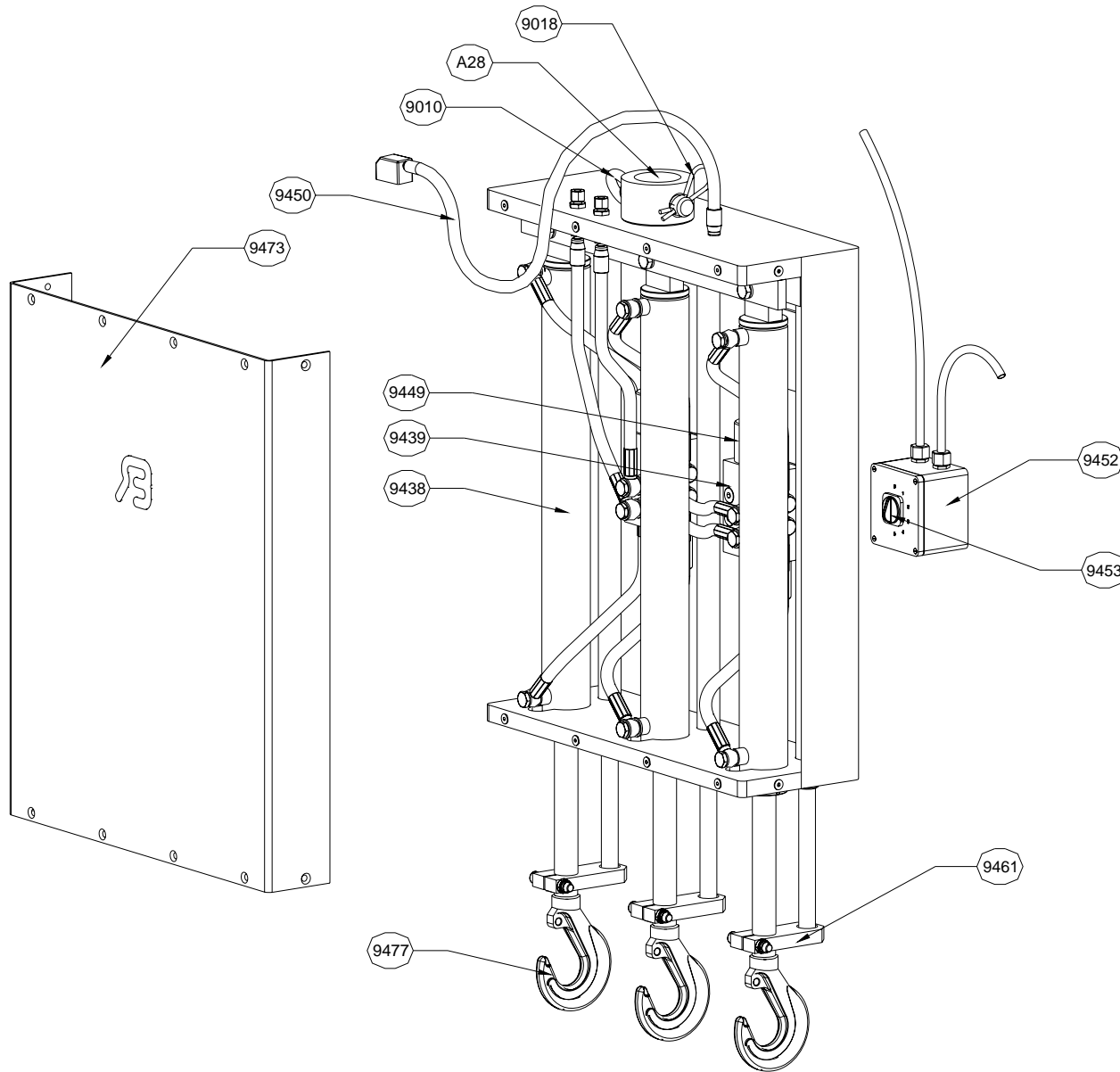

ONDERDELENLIJST

Nr.	Omschrijving	Aantal
A28	Adapterbus	1
9011	Adapterpen	1
9018	Borgveer t.b.v. adapterpen	1
9438	Cilinder 35-60-600 hakengrijper	3
9439	Wisselventiel hakengrijper compleet	2
9449	Spoel 24V t.b.v. wisselventiel 9439	4
9450	Aansluitslang GEJO 10/20	1
9451	Aansluitset inwendig GEJO 20	1
9452	Aansluitset incl. 5 standenschakelaar	1
9453	5 standenschakelaar	1
9461	Zuigerstanggeleiding standaard	3
9473	Beschermkap voor GEJO 10	1
9477	Haak t.b.v. cilinder rev. A	3



9438 Cilinder 35-60-600 rev. A GEJO 10/20

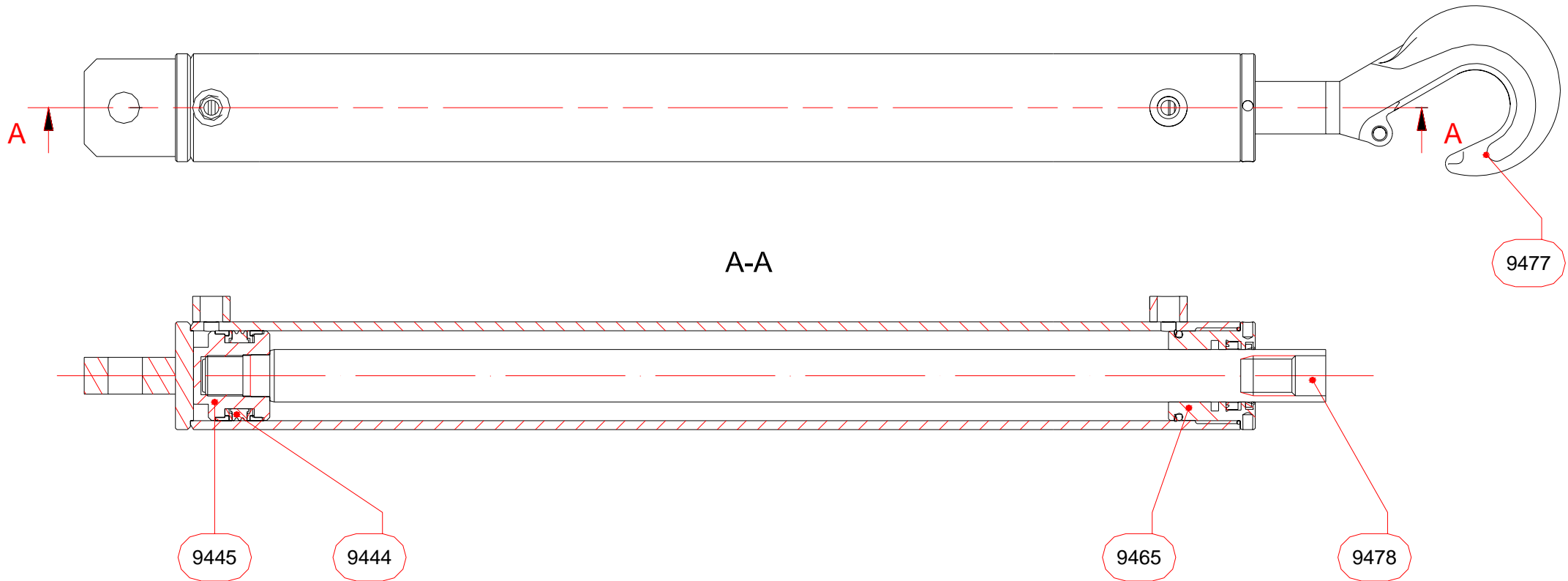

ONDERDELENLIJST

Nr.	Omschrijving	Aantal
9444	AFDICHTINGSET CILINDER 9437/9438	1
9445	ZUIGER CILINDER 9437/9438	1
9465	KOPMOER T.B.V. CILINDER 9437/9438	1
9477	HAAK T.B.V. CILINDER rev A	1
9478	ZUIGERSTANG CILINDER rev. A	1